

TECHNICAL DATA	UNIT.	ASA-100 PULLMAN	
DRUM			
Capacity 1:9 / 1:10	Kg	100 / 90	
Volume	l	900	
Diameter	mm	1.050	
Depth	mm	1.032	
Number of compartments	Nº.	2	
GENERAL DETAILS			
Washing speed / Spining speed	r.p.m.	45 / 750	
G Factor	-	325	
Maximum force transmitted	KN	25,27 ±5,87	
Frequency-dynamic force	Hz	12,5	
Sound level	dB	< 70	
Double drain	-	Opt	
Weighing System	-	Opt	
DOOR			
Height base door	mm	960	
Drum opening dimensions	mm	900 x 500	
Vat opening dimensions	mm	960 x 700	
POWER			
Motor	kW	15	
Electric heating	kW	60	
Max. power (Electric model)	kW	75	
Max. power (Hot water model)	kW	15	
Max. power (Steam model)	kW	15	
CONNECTIONS			
Tension 230V- I + N + T	Nº x mm2 / A	ELECTRIC	STEAM
Tension 230V- III + T	Nº x mm2 / A	-	-
Tension 400V- III + N + T	Nº x mm2 / A	4 x 50 / 160A	3 x 2,5 / 20A
Steam inlet (Steam mod.)	inch	3/4"	
Maximum steam consumption (Steam mod.)	Kg/h	34,2	
Water inlet	inch	1"	
Water main pressure	Kgs/cm ²	3-5	
Maximum water consumption*	Lit/h	900*	
Drain	mm/inch	2 x 3"	
Drainage capacity	Lit/min	2 x 200	
DIMENSIONS / PACKING DIMENSIONS			
Width / Width	mm	1.677 / 1.900	
Depth / Depth	mm	1.344 / 1.500	
Height / Height	mm	1.960 / 2.230	
Net weight / Gross weight	kg	1.900 / 1.958	
Volume	m ³	6,36	

* N°2 Program, 100% load

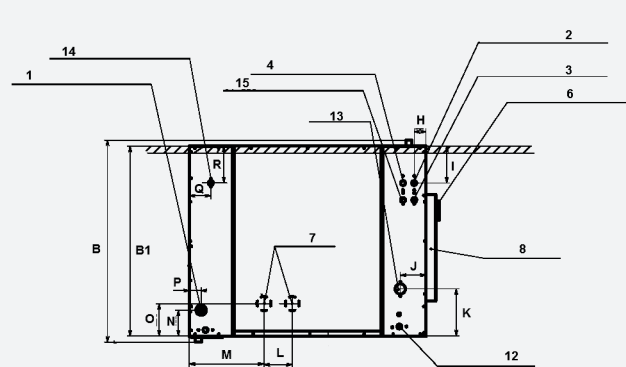
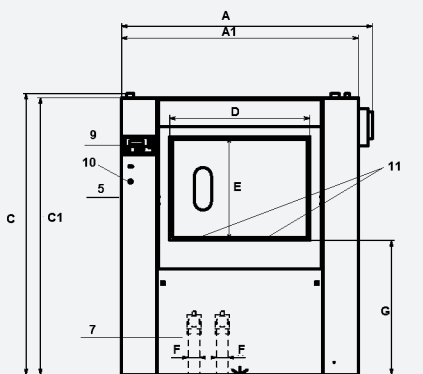

01. Electrical connection
02. Hot water
03. Cold water
04. 3rd water inlet (option)
05. Main switch
06. Liquid soap inlet
07. Drain
08. Soap box
09. Control panel
10. Emergency stop button
11. Door opening
12. Steam inlet
13. Vent
14. Compressed air
15. Water for soap box

	A	B	C	A1	B1	C1	D	E	F	G	H	I	J	K	L	M	N	O	P	Q	R
ASA-100	1.777	1.429	1.990	1.677	1.344	1.960	992	734	80	951	82	262	183	333	200	530	183	230	83	152	262