

TECHNICAL DATA	UNIT.	ASM-50 TOUCH	
DRUM			
Capacity 1:9 / 1:10	Kg	55 / 49	
Volume	l	489	
Diameter	mm	800	
Depth	mm	974	
Number of compartments	Nº.	1	
GENERAL DETAILS			
Washing speed / Spining speed	r.p.m.	45 / 900	
G Factor	-	350	
Maximum force transmitted	KN	14,07 ±3,51	
Frequency-dynamic force	Hz	15	
Sound level	dB	< 70	
Double drain	-	Opt	
Weighing System	-	Opt	
DOOR			
Height base door	mm	798	
Drum opening dimensions	mm	450 x 320	
Vat opening dimensions	mm	510 x 460	
POWER			
Motor	kW	5,5	
Electric heating	kW	36	
Max. power (Electric model)	kW	41,5	
Max. power (Hot water model)	kW	5,5	
Max. power (Steam model)	kW	5,5	
CONNECTIONS			
		ELECTRIC	STEAM / HOT WATER
Tension 230V- I + N + T	Nº x mm2 / A	-	-
Tension 230V- III + T	Nº x mm2 / A	3 x 25 / 125A	3 x 2,5 / 16A
Tension 400V- III + N + T	Nº x mm2 / A	4 x 16 / 63A	4 x 2,5 / 10A
Steam inlet (Steam mod.)	inch	3/4"	
Maximum steam consumption (Steam mod.)	Kg/h	23,275	
Water inlet	inch	1"	
Water main pressure	Kgs/cm ²	3-5	
Maximum water consumption*	Lit/h	450*	
Drain	mm/inch	3"	
Drainage capacity	Lit/min	200	
DIMENSIONS / PACKING DIMENSIONS			
Width / Width	mm	1.602 / 1.752	
Depth / Depth	mm	1.062 / 1.222	
Height / Height	mm	1.660 / 1.694	
Net weight / Gross weight	kg	1.056 / 1.090	
Volume	m ³	3,63	

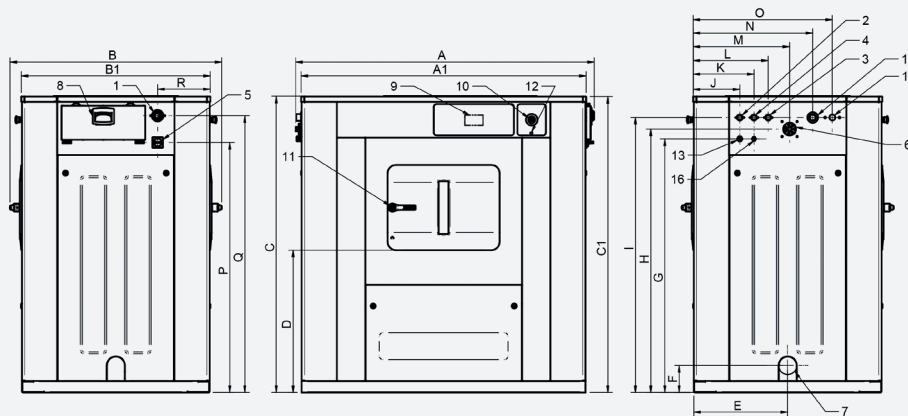

* Nº2 Program, 100% load

- 01. Electrical connection
- 02. Hot water
- 03. Cold water
- 04. Soft water
- 05. Main switch
- 06. Liquid soap inlet
- 07. Drain
- 08. Soap box
- 09. Control panel
- 10. Emergency stop button
- 11. Door opening
- 12. USB port
- 13. Pump connection for soap box
- 14. Steam inlet
- 15. Vent
- 16. Water for soap box

	A	B	C	A1	B1	C1	D	E	F	G	H	I	J	K	L	M	N	O	P	Q	R	S
ASM-50	1.679	1.190	1.662	1.602	1.062	1.660	798	528	152	1.478	1.543	262	342	422	542	682	1.423	1.403	1.553	296	-	-